

# QH Lip Shock Absorbers



QH Lip Shock Absorbers  
One Brand, One Reference,  
One Solution.



Big on Shock Absorbers

**Klarius**  
Group  
Excellence in Every Part



# We're 1st to market, you're 1st to profit.

Klarius Group is 1st when it comes to launching new innovative products, improving quality and enhancing safety.

With our new range of shock absorbers manufactured to OE quality they offer a massive cost saving against the original part. So you're the 1st to benefit.

One Brand - Klarius Group has collated its entire range of shock absorbers under one single brand name: QH Lip Shock Absorber.

One Reference System - We've co-ordinated stock number references by car application, and so reduced the need for complex and costly stockholding.

One Solution - Klarius Group products are the perfect match to OE parts. With more than 1,000 components covering 99% of Europe's most popular cars, you don't have to look anywhere else.

Think Big, talk to us today.



# Contents

**Page 4** QH Lip - The manufacturer

Who we are and our plant.



**Page 6** Unique construction

What a shock absorber does and how it works.

**Page 8** OE Technology and process

Safety, comfort and confidence.

**Page 10** Safety and comfort

What you need to know for a better ride.



**Page 12** Rally tested

We test our shocks to the limit.

**Page 13** QH Lip range

What the QH Lip range offers you.



**Page 14** The complete solution

Steering and suspension.

Suspensions spheres.

Protection kit.

Coil springs.



# QH Lip - The Manufacturer.

## Who are we?

Today, Klarius Group is Europe's biggest OE aftermarket manufacturer. We manufacture 100,000 car parts covering 99% of Europe's most popular cars. We operate 5 high volume Manufacturing Plants, a Research & Development Centre, 4 European Technical Centres, 8 International Logistics & Distribution Hubs and 18 national and regional Stock Warehouses, delivering to over 5,600 points in over 136 countries, 3 times a day. That's a big difference.

## QH Lip

QH Lip (part of the Klarius Group) has more than 60 years experience in shock absorber manufacture, for both Original Equipment and Aftermarket customers. Annually it produces more than 2 million shock absorbers and gas springs, many being fitted as standard to some of the world's



most prestigious car brands. However, it remains dedicated to its aftermarket customers.

QH Lip is a leader in the technical evolution of shock absorbers, constantly incorporating new materials and designs to deliver optimum performance and a long service life.



## Bilbao

Bilbao in Spain is the centre for research, product development and manufacture of QH Lip branded shock absorbers and suspension components. The plant has manufactured shock absorbers for Original Equipment and the automotive aftermarket for over 60 years. Since becoming part of the Klarius Group it has received significant new investment, incorporated a lean revolution within its manufacturing processes and in so doing has improved both quality and competitiveness.

The plant manufactures the whole range of shock absorber products including gas springs, protection kits and other related products, known all over the world for their OE pedigree and high quality standards.



Our proven manufacturing expertise has developed the latest technologies found in today's modern road vehicles.

Our quality systems ensure the effectiveness of internal processes and focus on delivering continuous improvements in every area of the business. We have been awarded BS EN ISO 9001 and 14001 certification.





# QH Lip Shock Absorbers - U

## What does a Shock Absorber do?

A shock absorber slows down the movement of springs to ensure good roadholding and a comfortable ride.

## How do they work?

A good shock absorber is one that is hard enough to prevent the wheel from leaving the ground and supple enough to ensure that the bodywork is not subjected to the force of the various bumps in the road.

### Mirrored internal finish.

Gives premium ride comfort.

### Valve Settings

#### + Comfort - Road Holding

- Comfortable ride
- Poor tyre/road contact
- Weaving under braking
- Poor road-holding

#### + Road Holding - Comfort

- Hard ride
- Good tyre/road contact
- Better stability
- Good road holding

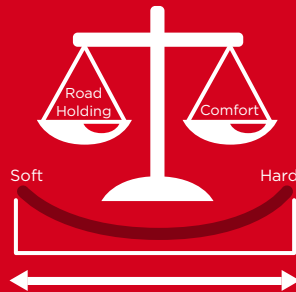

### One piece, heat sealed tube.

Eliminates leaks.

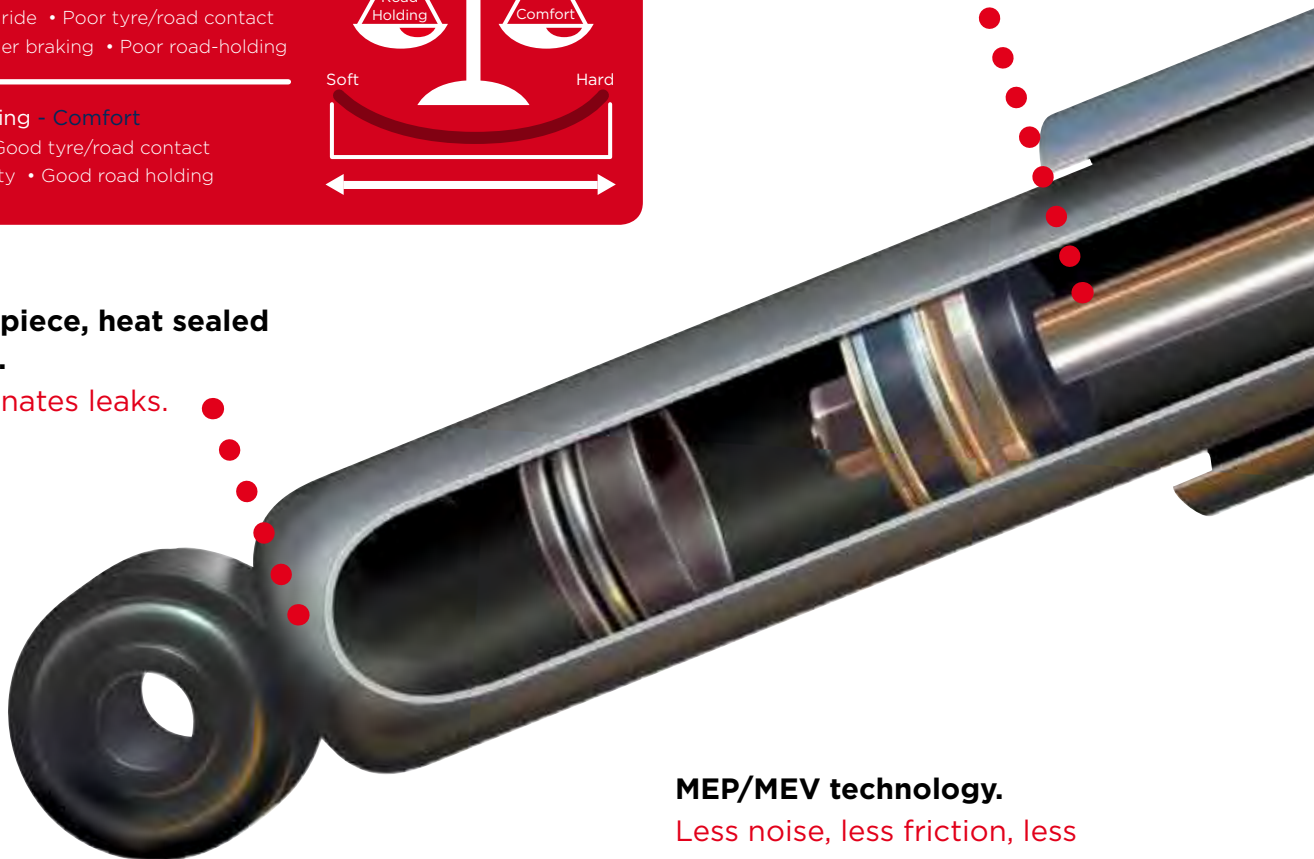

### MEP/MEV technology.

Less noise, less friction, less emulsification.

## MEP (Multiple Effect Piston) Technology

- Up to 5 discs used with a variable number of holes.
- Characteristics can be fine tuned to the specific vehicle application.
- Precision controlled oil flow throughout full working stroke in both compression and extension.

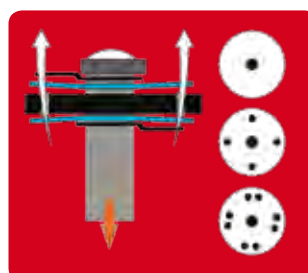

# Unique Construction.

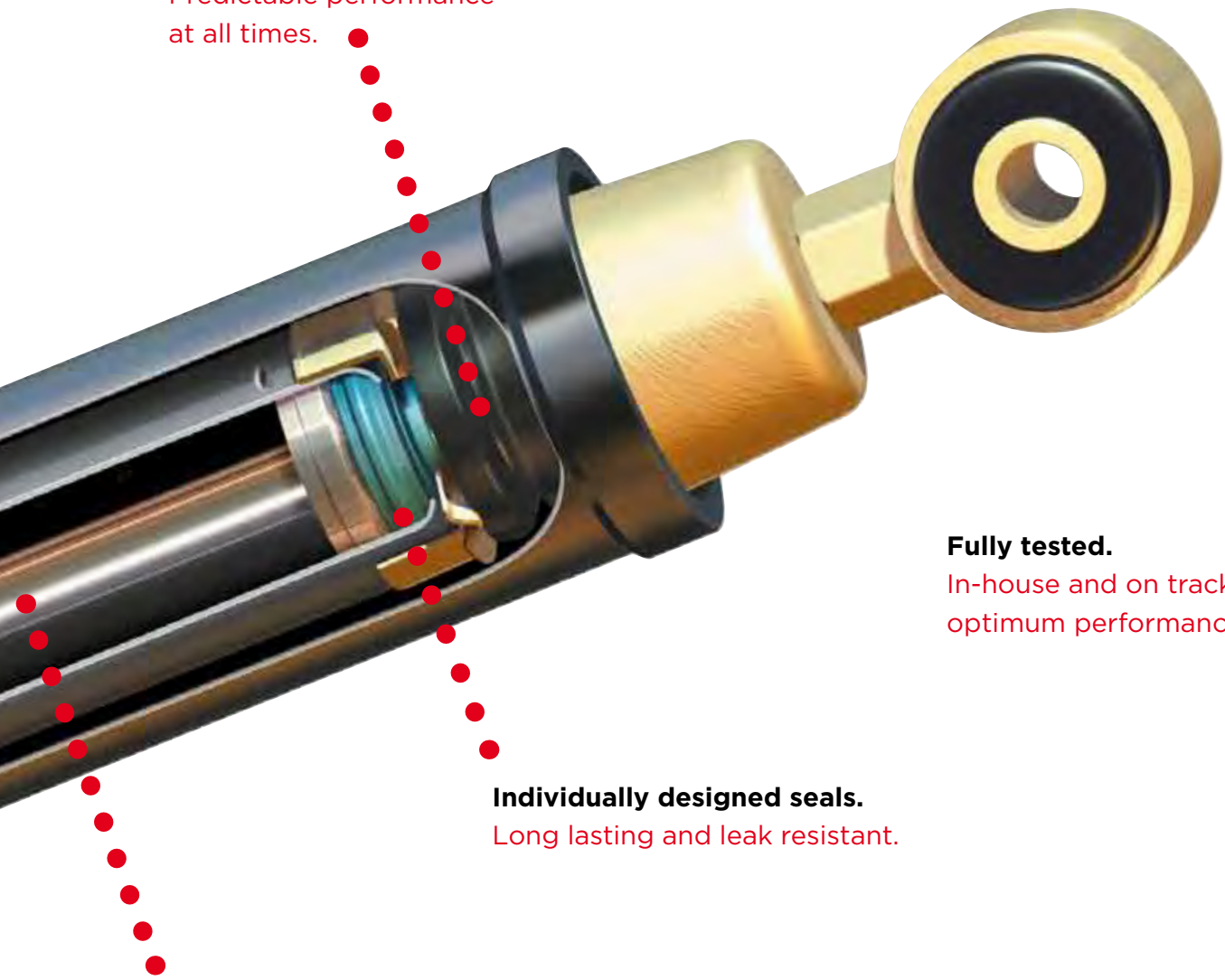

**Unique seal material.**

Predictable performance  
at all times.

**Made to OE specification.**

Delivers manufacturer ride  
quality.

**Fully tested.**

In-house and on track for  
optimum performance.

**Individually designed seals.**

Long lasting and leak resistant.

**Chromed piston rods.**

Made to OE specification  
for long life.

QH Lip shock absorbers: where better road holding, safer braking, improved comfort and better value come as standard.

# OE Technology and Certification

## CAD/CAM

- In-house design for all products.
- WINDOWS NT system.
- Autocad mechanical 6, Windows 7 and solid works 2010.
- Hardware DIGITAL platform.
- Re-focussed NTR development programme introducing more than 200 new European and Non-European model parts per year.

That's equivalent to one per working day, with recent introductions including the latest versions of the Citroen C3, Opel Astra, Renault Megane (3) and Ford Fiesta (6).



1. Pre-production prototype.



2. Durability/r

## Equipment

In-house testing facilities both on test rigs and on private test track.

## Tests

100% mapping test to ensure that each shock absorber performs to the OE performance criteria for each specific application.



8. Safety and comfort for the end user.



## Certification

QH Lip certifies and guarantees that our products fulfil the quality requirements applicable to the use of spare parts for repair or maintenance of motor vehicles by authorised repairers in accordance with ART.1(T) 'original parts' or (U) 'replacement parts' of the block exemption regulation (EC) 1400 2002 of the European Community.

The present ISO9001 and ISO14001 certificates, together with the previous approvals from our vehicle manufacturer customers and our guarantee of compliance with the new standard BER1400/2002 of the European Community, ratify the strategic focus of our business upon TOTAL QUALITY through CONTINUOUS IMPROVEMENT. In short, upon the satisfaction of all our customers.



7. Certification.



# ation process.



Reliability testing.



3. Performance testing to meet OE standards.



4. Driver satisfaction testing.



5. Production.



6. 100% mapping test, ensures each shock absorber performs to OE performance criteria for each specific application.



# Safety, Comfort and Confidence.

## Safety

- QH Lip shock absorbers offer greater safety under braking
- Rigorously meet or exceed the performance of the original unit.
- Not compromised by the use of a standardised design across a range of vehicles.



## Comfort

- Provide a higher control of pitch and sway, neither 'harder' nor 'softer' than the car designer's specifications.
- Complete elimination of noise.
- Shock performance perfectly matched to the vehicle.

## Confidence

- Three year guarantee against material or manufacturing defects.
- Quality certifications ISO9001:2000 and major vehicle manufacturers' approvals, as required for OE supply.
- Technology proven on the race track.

## Worn shock absorbers

Worn shock absorbers allow the wheels to bounce, especially on poorer road surfaces. Tyres which are not in contact with the road can do little to stop the car when the brakes are applied.

If you detect any of the signs below it may be time to have your shocks inspected.



Steering wheel vibrates.

Bald patches on tyres.

Car nose dives when braking.

Car veers in high winds.

Car does not hold the road on bends.

Oil seeps from your shock absorbers.

# Stopping distances increase with worn shock absorbers.

Stopping distance  
at 50mph



Stopping distance  
at 70mph



# QH Lip Shock Absorbers - Rally Tested.

## The ultimate test.

We rely on our components to perform in a competitive rallying environment.

And we're determined to ensure that all our customers can rely on everything we manufacture.



# What the QH Lip range offers you.

- First to market.  
So you're the first to profit from new products.
- Lower stockholding.  
High service with less lines, less money tied up in stock.
- QH manufactured.  
Trusted suppliers for over 60 years.
- Unbeaten availability.  
Complete coverage of Europe's most popular cars.
- In-house testing.  
100% mapped, test track and rally proven.
- Simple referencing.  
New system makes ordering easy.
- Most active new to range programme.  
So you're first to market and first to profit.
- One stop shop.  
All your steering & suspension needs from just one supplier.

At QH Lip we focus on bringing new and innovative products to market, before anyone else. In fact we develop a new to range product every single working day.

And, as we manufacture our products at our own plants, we can quickly and efficiently respond to your requests for specific range shortages.

This enables you to offer your customers greater cost savings before anyone else too.

That's a big difference.



# The complete steering and s

## The complete range.

The Klarius QH steering & suspension range comprises of:

- Inner tie rods
- Tie rod ends
- Rod assemblies
- Ball joints
- Track control arms
- Wishbones
- Link stabilisers
- King pin sets
- Steering kits

And with new references continuously being developed, we can ensure our customers have the most comprehensive and up-to-date range of products available in Europe today.



## Suspension spheres.

These are an integral part of your steering and the overall handling and control of the vehicle.

QH offer the complete range for the majority of vehicles on the road today.



# suspension solution.



## Protection kit.

It is best practice to change the gaiters and Shock Absorber Bump Stops when renewing a shock absorber.

- Sold as a pair to cover the complete axle.
- Helps to prevent the ingress of dust and moisture protecting the piston rod and seal.
- Protects the piston rod from stone impact damage.
- Increases the life of the shock absorber.
- Limits the suspension travel in the compression phase.
- Reduces time if changed at the same time as the shock absorber.

We additionally offer a range of top strut mountings and bearings.



## Coil springs.

QH offer the complete range of coil springs compatible with all the different types and designs used by vehicle manufacturers.

Each spring is carefully designed to replicate all of the original design characteristics required by the vehicle manufacturer and is 100% quality controlled and tested prior to shipment.

The range has been optimised for the aftermarket.

QH range is not over simplified. If a new spring does not fall within the design parameters required by the OE a new part number will be introduced to cover that application.



QH Lip - Your one  
stop shop for all  
your steering and  
suspension needs.

[www.qh.com](http://www.qh.com)

**Klarius**  
Group



Excellence in Every Part